

MetaCenter DCO

Identification: Kit, MetaCenter DCO2, DCO3 & DCO4
Part number: Refer to Product guide / price list for specific part number or contact dealer
Product Family: MetaCenter
Function: Central management control & monitoring of air / gas compressors
 Optional integrated control / monitoring of ancillary compressed air equipment
Definition: Narrow pressure band controller with enhanced software features & functions
Capacity: 2, 3 or 4 air / gas compressors & MetaCenter ancillary product control / monitoring via optional MetaCenter I/O & sensor options
Compressor connectivity: DCO Series terminal board & dedicated compressor interface or via **Air^{RS485}** communication protocol
Supported protocol: **Air^{RS485}** & Modbus RTU via dedicated network gateway
Software: Pre-programmed application software, configurable via password protected operator interface

Product overview:

As demand for compressed air fluctuates and as system pressure decays or increases in response to that demand, MetaCenter compressor management systems ensure that site wide compressors and ancillary compressed air equipment are harnessed as 1 to obtain an equilibrium where efficiency, equipment utilisation and system pressure are in perfect balance. In unmanaged compressed air systems that equilibrium represents a significant energy & cost saving opportunity.



MetaCenter DCO is a specialised supervisory control product designed to provide energy efficient optimised narrow pressure and priority management control of up to 4 air / gas compressors operating in a common compressed air / gas system. Each DCO kit is provided with a quantity of compressor interface PCB's (mi-PCB) and a 4-20mA / 0-232 psi (0-16bar) pressure sensor.

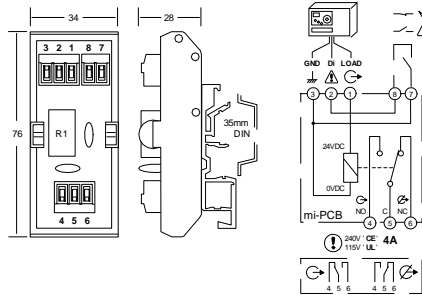

MetaCenter general operating mode can be modified via a number of adjustable parameters enabling its control strategy to align with & optimise available compressed air equipment and site specific installation characteristics.

Features & Functions:

The primary function of the MetaCenter DCO's pressure control strategy is to maintain system pressure between the 'High Pressure' set point & the 'Low Pressure' set point in conjunction with targeting energy efficiency through optimal compressor utilisation. The MetaCenter calculates a 'Target' pressure level which is used as the nominal 'target' pressure level for the system. Rate of change in pressure, is largely determined by system volume and the scale, and/or abruptness, of air demand fluctuations; these characteristics will differ from installation to installation. To accommodate for variations in installation characteristics the 'Tolerance' pressure level (tP) and an influence on the dynamic reaction time (or 'Damping' (dA)) of the MetaCenter is adjustable.

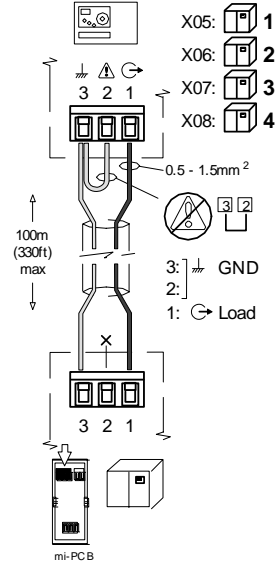

Key product features:



One touch & single pressure band technology narrowing site wide pressure to a minimum of 2.9psi (0.2bar)



Remote I/O expansion. Add distributed intelligence to monitor equipment, sensors and automate functions

Sullivan-Palatek[®]

Product Family: MetaCenter
 Function: Central management control & monitoring of air / gas compressors
 Optional integrated control / monitoring of ancillary compressed air equipment
 Definition: Narrow pressure band controller with enhanced software features & functions
 Capacity: 2, 3 or 4 air / gas compressors & MetaCenter ancillary product control / monitoring via optional MetaCenter I/O & sensor options
 Pressure ref: 4 – 20mA
 Pressure scale: Configurable to 957psi (66bar)
 Processor: 8 bit micro controller 80C51 family
 Op. interface: 1.8" (45mm) x 1" (25mm) backlit LCD with custom alpha-numeric / symbolic graphics...



Software: Pre-programmed application software, configurable via password protected operator interface
 Protocol: **Airbus RS485™** & Modbus RTU via dedicated network gateway
 Modes of control: Timer rotation
 Software features: Sequence rotation, Priority settings
 Auxiliary output: 1 x Menu selectable single function relay output ² (² see function list below)
 Auxiliary input: 2 x Menu selectable single function digital input ¹ (¹ see function list below)
 Alarm input: Alarm detection input from connected compressor (C1 through C4 relative to DCO type)
 Supply / Power: 100 – 240vAC, 100VA
 Enclosure rating: IP54 / NEMA12
 Dimensions: Height: 6.3" (160mm) x Width: 10" (253mm) x Depth: 3.6" (90mm)

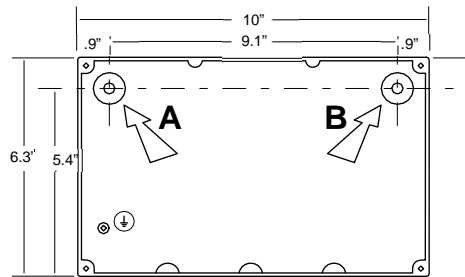
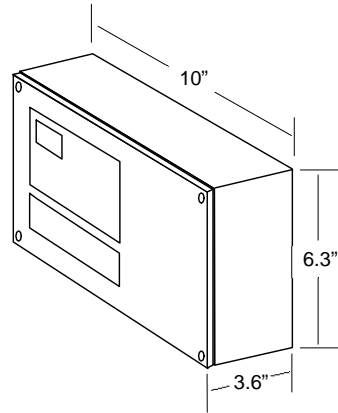

Access: Front, tool secured access panel
 Cable entry: Bottom, gland cable entry system
 Weight: 5lb (2.2kg)
 Mounting: Wall, 2 x screw fixing
 Temperature: Min 32°F (0°C), Max 115°F (+46°C)
 Humidity: 95% RH non-condensing
 Approvals: CE, UL, cUL

¹ Auxiliary digital inputs – Function list:

- Disable – no function (default configuration)
- Remote start / stop
- Remote alarm
- Remote alarm - delayed
- Remote trip
- Remote trip - delayed

² Auxiliary relay output – Function list:

- Any alarm - DCO or connected compressor with feedback to DCO (default configuration)
- Compressor 'Not OK' fault only
- DCO state (started, active & running)
- Low pressure alarm

